

Steam Washing System SWS100 For Polaris™ process refractometers

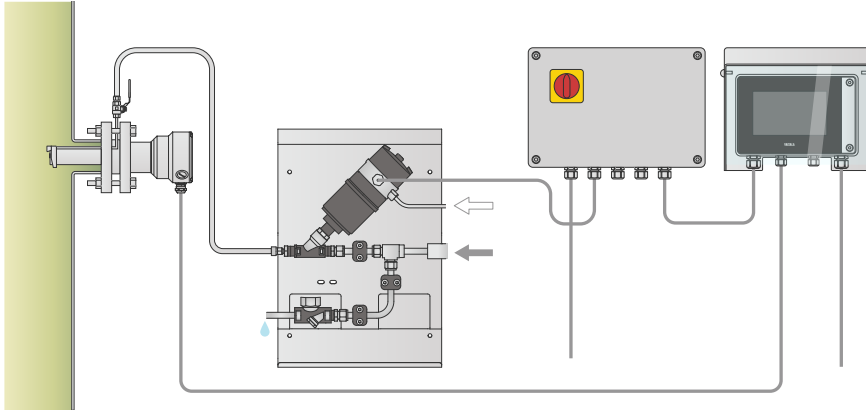

Features

- Complete system for steam wash
- Inlet pressure 2 ... 8 bar above process pressure (max. 19 bar with optional pressure reducer)
- Strainer, valves, and condensate trap included
- Compatible with Polaris™ PR53 series refractometers
- Wash control with Vaisala Indigo520 Transmitter

The SWS100 steam washing system adds a field-proven wash solution to the Polaris™ process refractometer series. When the measured process medium is sticky or the process flow is not sufficient to maintain the prism cleanliness, the periodic steam wash system provides a reliable method to clean the prism. This ensures stable measurement in demanding applications, such as concentrated black liquor, sugar mills, fatty dairy products, or food ingredients.

Benefits

The flowing steam and high temperature of the SWS100 steam washing system effectively remove residues that might have accumulated on the refractometer prism, ensuring measurement accuracy in challenging applications where prism cleanliness might otherwise be compromised.

The field-proven system provides high-quality, particle-free and condensate-free steam with optimal pressure to be used for the wash system. The components and the system design are based on the success and 40 years of field experience from Vaisala K-PATENTS® process refractometers in various industries and applications.

Principle

In the steam washing system, high-pressure steam is flushed through a wash nozzle with high speed. The wash nozzle is installed so that the steam flow is

directed on the prism in an optimal angle and distance. SWS100 contains all necessary components to implement a steam washing system: strainer, condensate trap, shut-off valve with solenoids, and a steam pipe. Optional pressure reducer is available. The check valves and the wash nozzle are included in the Polaris process refractometer or flow cell.

Right pressure

The recommended pressure for steam wash is 2 ... 8 bar above the process pressure. The optional pressure reducer is available when the steam supply exceeds the recommended steam pressure. The pressure reducer is equipped with flanged steam line connections and membrane materials which are suitable for continuous temperature cycling. The integrated pressure gauge allows easy inspection of the regulated pressure.

No condensate

Condensate removal is the most critical part of a steam wash solution. High-quality, field-proven condensate trap combined with comprehensive installation instructions ensure that the steam supplied to the wash nozzle is free from condensate, which is critical for a successful steam wash.

Indigo520-controlled

The wash cycles are controlled by dry contact switches included in the Indigo520 transmitter. Indigo520 provides an easy-to-use user interface for configuring and controlling the wash sequence and the necessary diagnostic tools for verifying the wash cycle efficiency. Alternatively, when Indigo520 is not used, the washes can be controlled with a standard PLC relay.

Technical data

Operating environment

Operating temperature	+0 ... +50 °C (+32 ... +122 °F)
Storage temperature	-30 ... +60 °C (-22 ... +140 °F)
Operating humidity	0-100 %RH, non-condensing

Supply parameters

Control voltage	24 V DC
Power consumption	< 1 W

Steam parameters

Maximum pressure (component specification)	20 bar (290 psi) (without pressure reducer) 12 bar (174 psi) (with pressure reducer)
Maximum operating temperature	+230 °C (446 °F) (volume max. 4.8 l ³ -140 l ³ /h)
Compressed air supply	3-7 bar (volume min. 250 l (66 gal) / min) Oil-free instrument air

Typical wash pressures

Wash nozzle	Concentration value	Minimum above process pressure	Maximum above process pressure
Integral wash nozzle in PR53AP/GP	n/a	2 bar (30 psi)	4 bar (60 psi)
Sanitary Elbow Flow Cell SEFC wash nozzle	n/a	3 bar (45 psi)	6 bar (90 psi)
PR53SD wash nozzle	10-30 %	2 bar (30 psi)	4 bar (60 psi)
	30-60 %	3 bar (45 psi)	6 bar (90 psi)
	60-90 %	5 bar (72.5 psi)	8 bar (120 psi)

Compliance

EU directives and regulations	RoHS Directive (2011/65/EU) as amended by 2015/863 Pressure Equipment Directive (2014/68/EU)
-------------------------------	---

Mechanical specifications

Check valve	AISI 316, FFKM ¹⁾
Angle piston valve connections (electricity and air)	Multipole M12, 8-pin Cable gland M16×1.5 (cable Ø 5-10 mm / 0.2-0.4 in) with screw terminals for cable cross sections 0.14-1.5 mm ² Supply pressure 3-7 bar (43.5-101.5 psi) Pilot air ports threaded connection G1/8 stainless steel or push-in connector (pipe Ø 6 mm / 1/4")
Outlet	1/2" NPT F or 3/8" pipe fitting (included) EN 1.4404
Inlet	1/2" NPT F or 1/2" tube fitting with pressure reducer EN 1.4404
Drain	1/2" NPT F EN 1.4404
Steam strainer	Mesh: 100
Back plate	EN 1.4044

¹⁾ 2.1 certificate included.

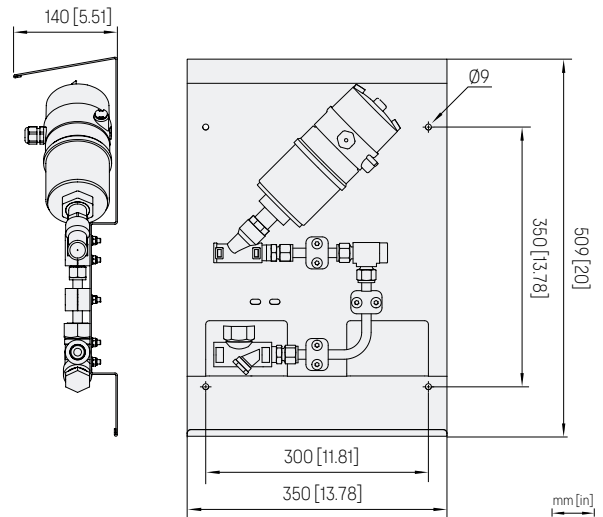

SWS100 main assembly dimensions

ERT52 technical data

The ERT External Relay Terminal contains:

- Two 3-phase contactors
- Overload protection
- Timer relay
- Main switch

ERT controls the pump and the water valve of the pump.

ERT is controlled with Indigo520 control relay.

Operating environment

Operating environment	Indoor use Outdoor use
Use in wet location	No
Operating temperature	+0 ... +50 °C (+32 ... +122 °F)
Storage temperature	-30 ... +60 °C (-22 ... +140 °F)
Operating humidity	0-100 %RH, non-condensing
Pollution degree	2 (Non-conductive pollution)
Maximum operating altitude	2000 m (approx. 6500 ft)

Enclosure specifications

Property	Description/Value
Material	Aluminum painted with RAL color 7001
Size (length x width x height)	330 × 230 × 110 mm (12.99 × 9.06 × 4.33 in)
Weight	3.6 kg (7.94 lb)
IP rating	IP66
UL 50E/NEMA rating	Type 4
IK rating	IK 08
Cable glands	M20 × 1.5, 5-9 mm (0.2-0.35 in) cable diameter
Conduit hub	M20 × 1.5 / 1/2" NPT
Dummy plug	M20 × 1.5 / 6 mm (0.24 in)

Inputs and outputs

Operating voltage	110 V AC ±10 %, 60 Hz (1-phase) 230 V AC ±10 %, 50 Hz (1-phase)
Maximum power consumption	25 W
Control signals	24 V DC ±10 %, max. 20 W (generated by internal PSU)
Overvoltage category	II
Mains supply fuse (not included)	Max. 10 A (slow)

Compliance

EU directives and regulations	EMC Directive (2014/30/EU) Low Voltage Directive (2014/35/EU) RoHS Directive (2011/65/EU) as amended by 2015/863
Safety	IEC/EN 61010-1
Compliance marks	CE, China RoHS, RCM, UKCA
FCC compliance	FCC part 15 B, Class B

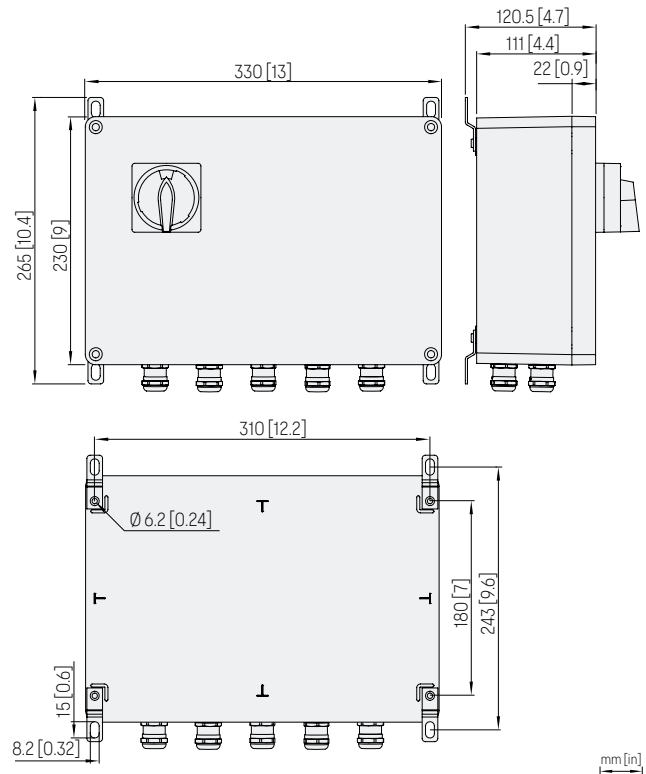

ERT enclosure dimensions